

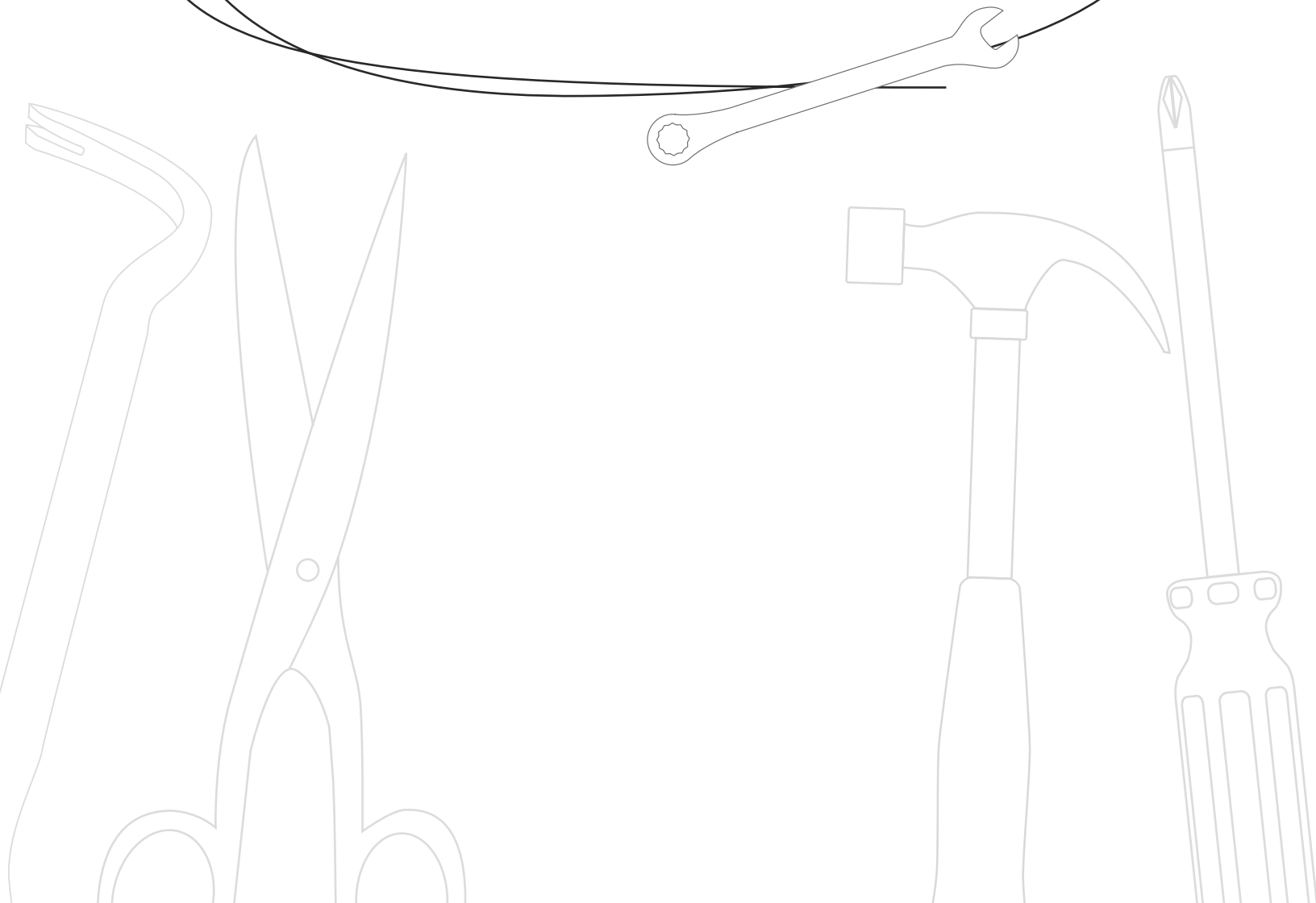

We Get the Job Done.

Core Bench & Upper Deck Workbench

ASSEMBLY INSTRUCTIONS



Contents



- 03** ▪ Required Tools
- 04** ▪ Fully Welded Workbench Assembly Instructions
- 05** ▪ Bolt Together Workbench Assembly Instructions
- 06** ▪ Upper Unistrut Installation Instructions
- 07** ▪ Upper Shelf Installation Instructions
- 08** ▪ Power Strip Installation Instructions
- 09** ▪ Overhead Light Installation Instructions
- 10** ▪ Monitor Mount Installation Instructions
- 14** ▪ Bin Rail Installation Instructions
- 15** ▪ Keyboard Installation Instructions
- 16** ▪ File/Utility Drawer Installation Instructions
- 17** ▪ Lower Shelf Installation Instructions

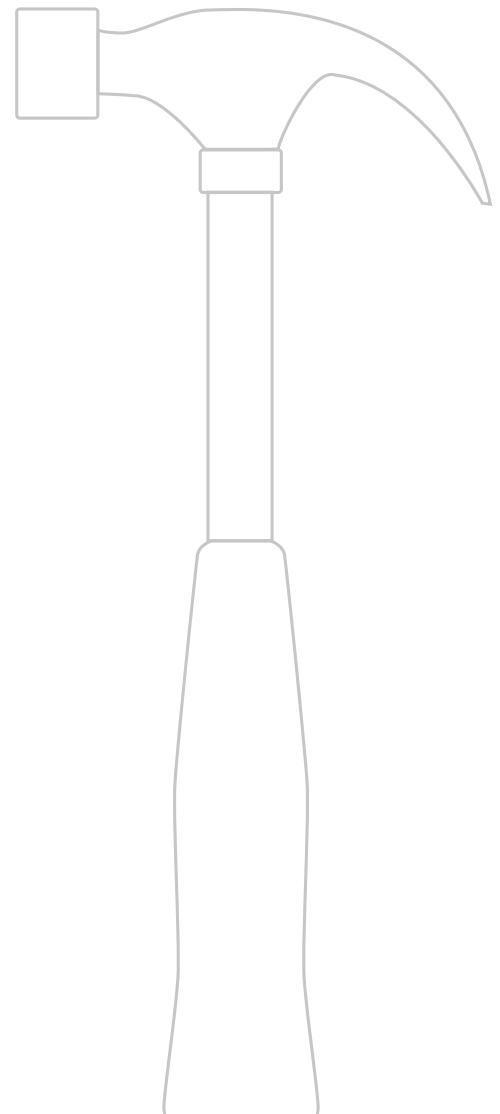

Required Tools



#2

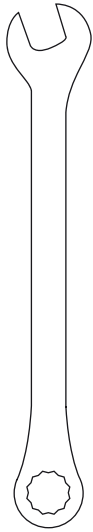

9/16

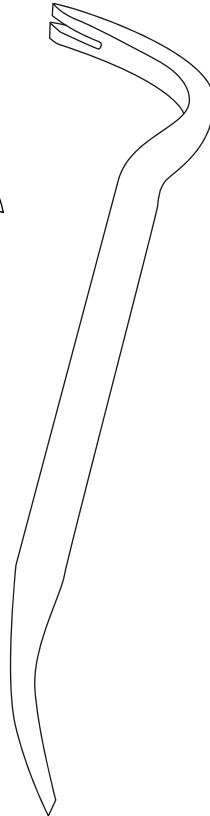
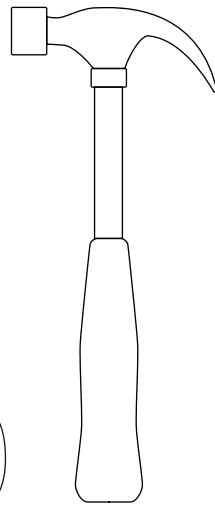
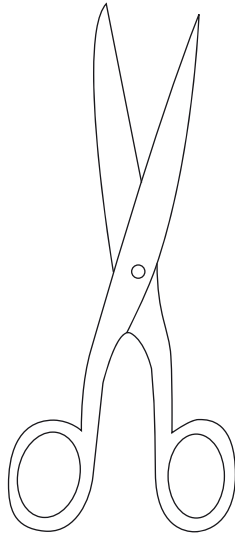

Please completely inspect the contents of your order. Do not sign the bill of lading until you are satisfied that all components are present and undamaged.

Favor de inspeccionar totalmente los contenidos de su orden. No firme el recibo de carga hasta que es seguro de que todos los componentes están completos y sin daño alguno.

Use the hammer and/or crowbar to take the crate apart, taking care not to scratch the bench.

Use el martillo o una palanca para abrir la caja de embarque, teniendo cuidado de no dañar la banca.

Use the shears to cut the strapping tape and unpack the bench.

Use las Tijeras para cortar la cinta de empaque y saque la banca.

Fully Welded Workbench Assembly Instructions

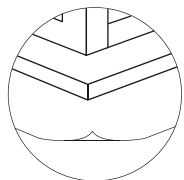

Place the bench on packing material to protect the worksurface during assembly.

Coloque la banca sobre el material del empaque para proteger la superficie durante el proceso de armar.

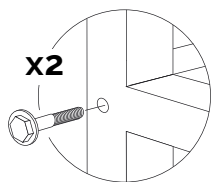
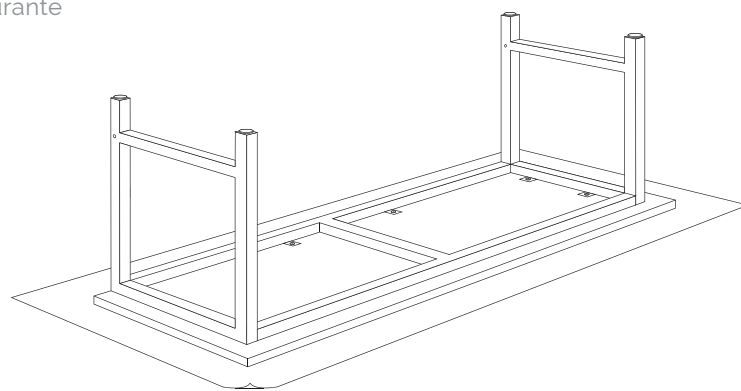

Bolt the spreader bar to the back legs.

Atornille la barra de extensión atrás de las patas.

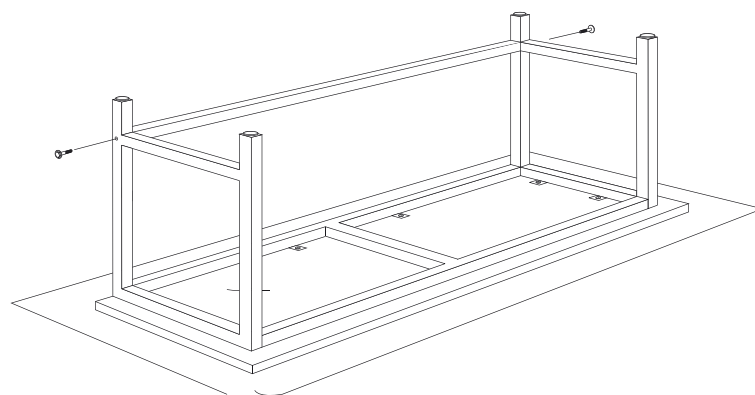

Bolt Together Workbench Assembly Instructions

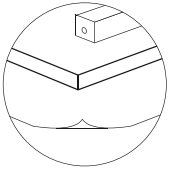

Place the bench on packing material to protect the work surface during assembly.

Coloque la banca sobre el material del empaque para proteger la superficie durante el proceso de armar.

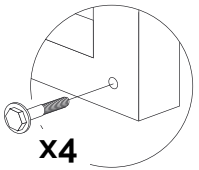
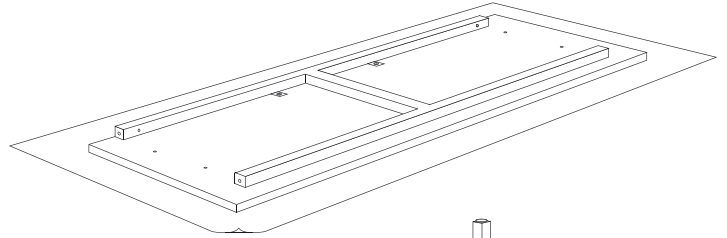

Bolt the legs to the frame with the tabs on the legs pointing inward.

Atornille las patas al marco con las orejas apuntando hacia adentro.

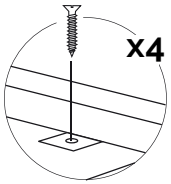
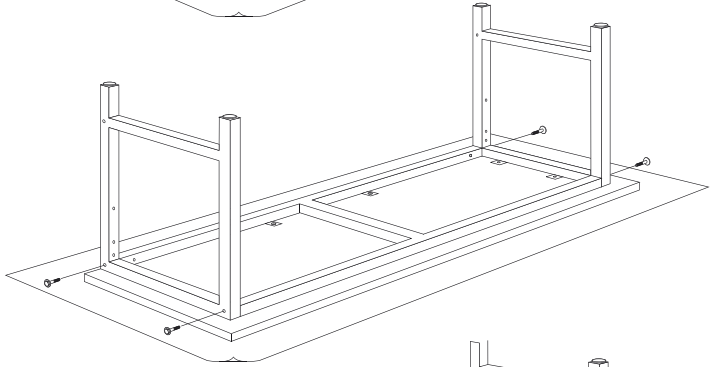

Screw the the tabs to the work surface.

Atornille las orejas a la superficie.

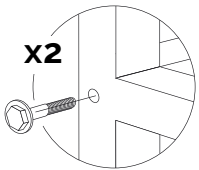
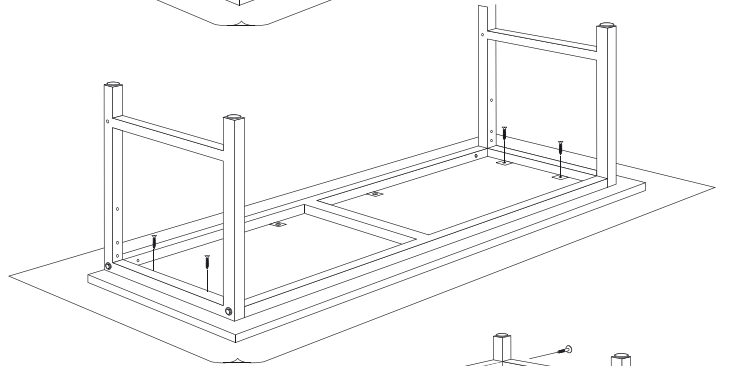

Bolt the spreader bar to the back legs.

Atornille la barra de extensión atrás de las patas.

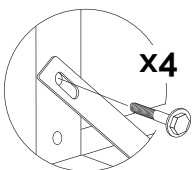
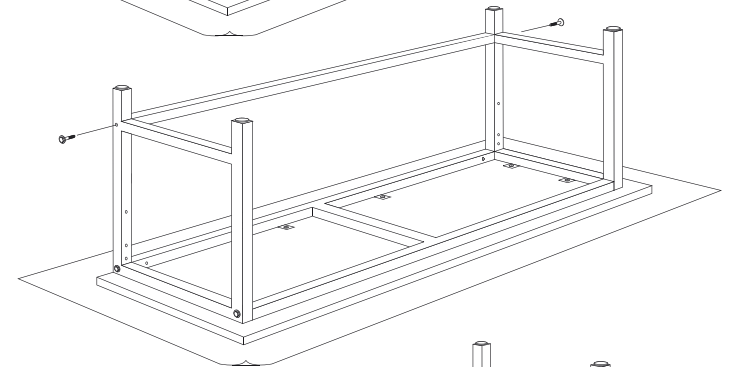

Bolt the two gussets to the back legs.

Atornille los dos refuerzos (codos) atrás de las patas.

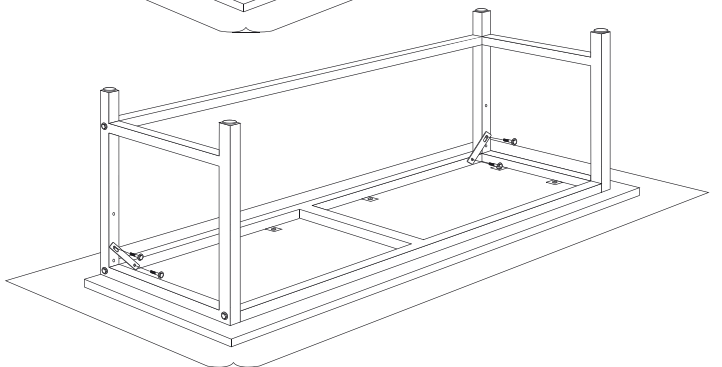

Upper Unistrut Installation Instructions

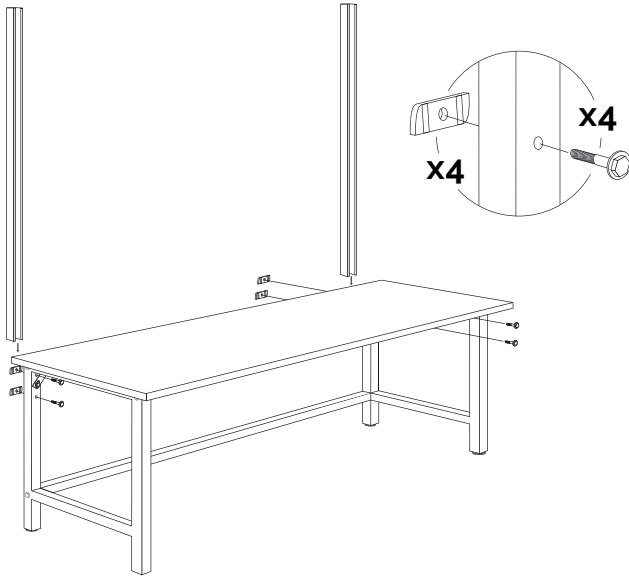

Insert bolts through back legs and loosely attach cone nuts in a horizontal position. Slide struts down over cone nuts and tighten bolts.

Meta los tornillos por atrás de las patas y ponga los pernos. Deslice las tuercas y apriete los tornillos.

Insert bolts through brackets and loosely attach cone nuts in a vertical position. Insert cone nuts into struts.

Meta los pernos a través de los soportes y atornille ligeramente las tuercas del cono en posición vertical. Meta las tuercas en los puntales.

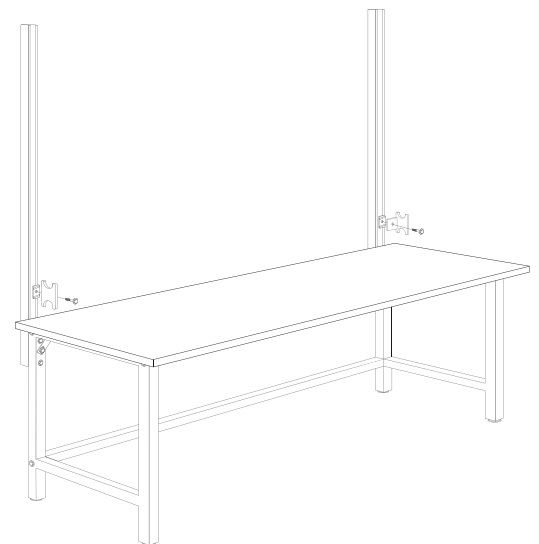
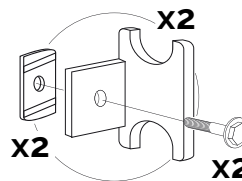

Rotate cone nuts to a horizontal position inside the strut and tighten bolts. Place roller bar on top.

Gire las tuercas hasta que estén en posición horizontal dentro del puntal y apriete los pernos. Coloque arriba la barra del rodillo.

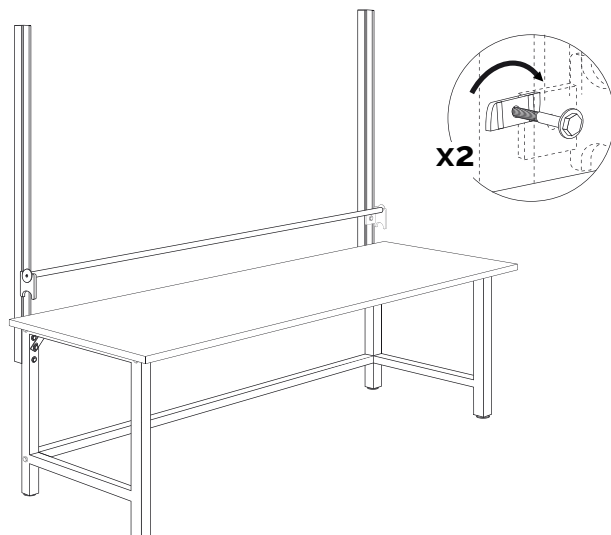

Upper Shelf Installation Instructions

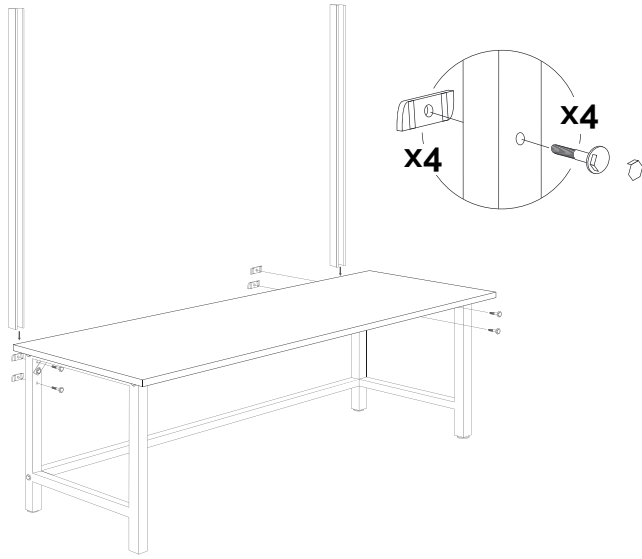

Place shelf on work surface. Insert bolts through shelf and loosely attach cone nuts in a vertical position. Insert cone nuts into struts.

Coloque el anaquel en la superficie de trabajo. Ponga los tornillos a través del anaquel y proceda a poner las tuercas en posición vertical. Ponga las tuercas a los puntales.

Insert bolts through back legs and loosely attach cone nuts in a horizontal position. Slide struts down over cone nuts and tighten bolts.

Meta los tornillos por atrás de las patas y ponga los pernos. Deslice las tuercas y apriete los tornillos.

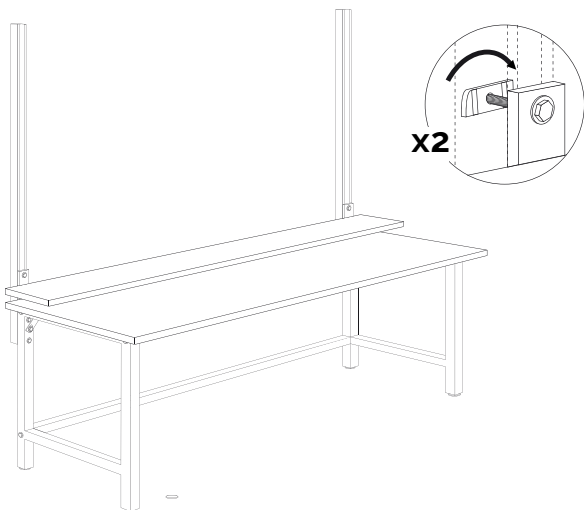
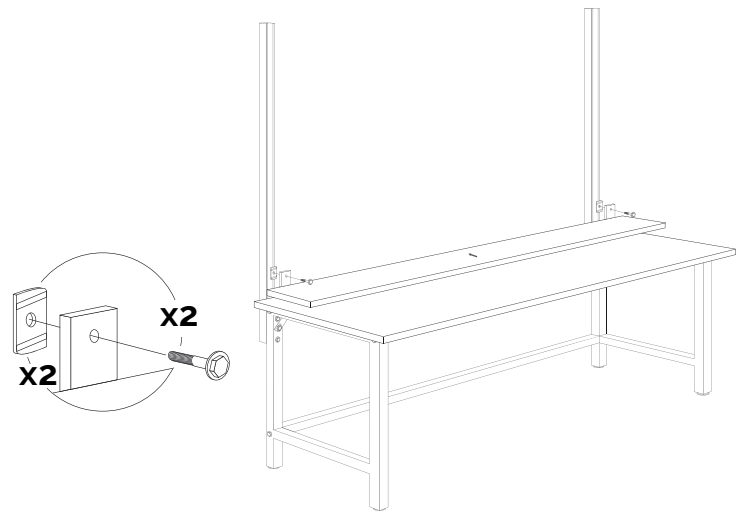

Rotate cone nuts to a horizontal position inside the strut.

Dele vuelta a los tornillos has que queden en posición horizontal dentro de los puntales.

With the help of another person, raise shelf and tighten bolts.

Con la ayuda de una segunda persona, levante el anaquel y apriete los tornillos.



Power Strip Installation Instructions

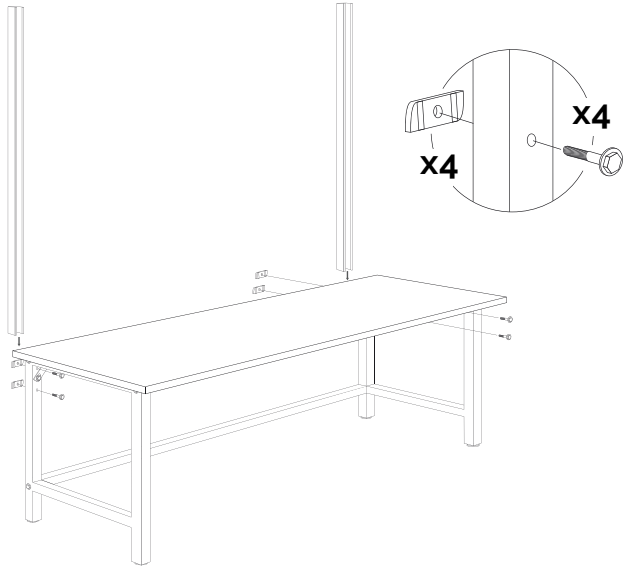

Insert bolts through back legs and loosely attach cone nuts in a horizontal position. Slide struts down over cone nuts and tighten bolts.

Meta los tornillos por atrás de las patas y ponga los pernos. Deslice las tuercas y apriete los tornillos.

Insert bolts through power strip and loosely attach cone nuts in a vertical position. Insert cone nuts into struts.

Ponga los tornillos a través del cordón eléctrico y meta las tuercas en posición vertical. Meta las tuercas en los puntales.

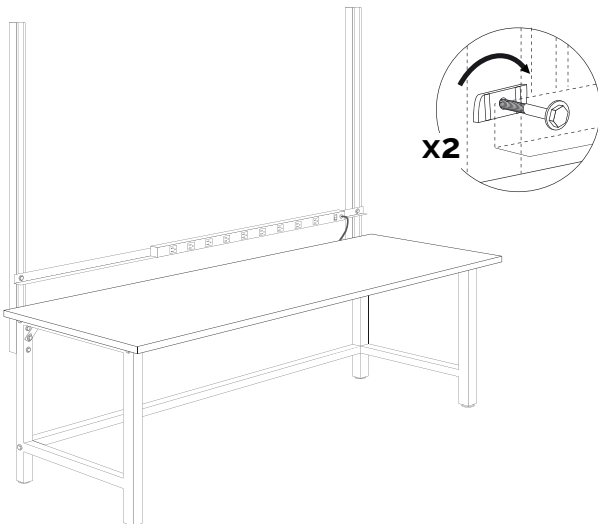
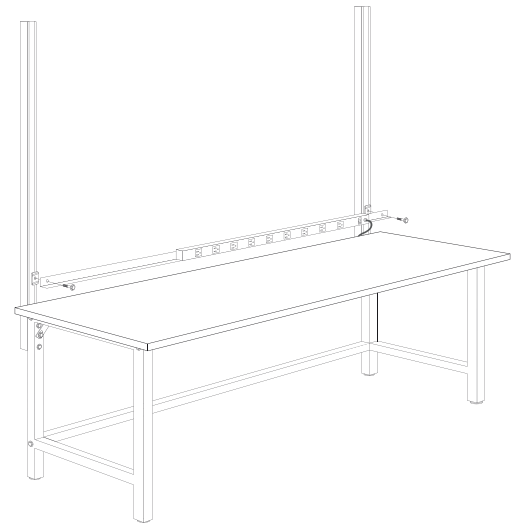
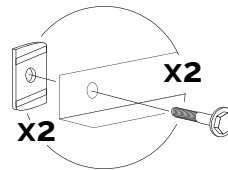

Rotate cone nuts to a horizontal position inside the strut and tighten bolts.

Haga girar las tuercas del cono a una posición horizontal dentro del puntal y apriete los tornillos.

Overhead Light Installation Instructions

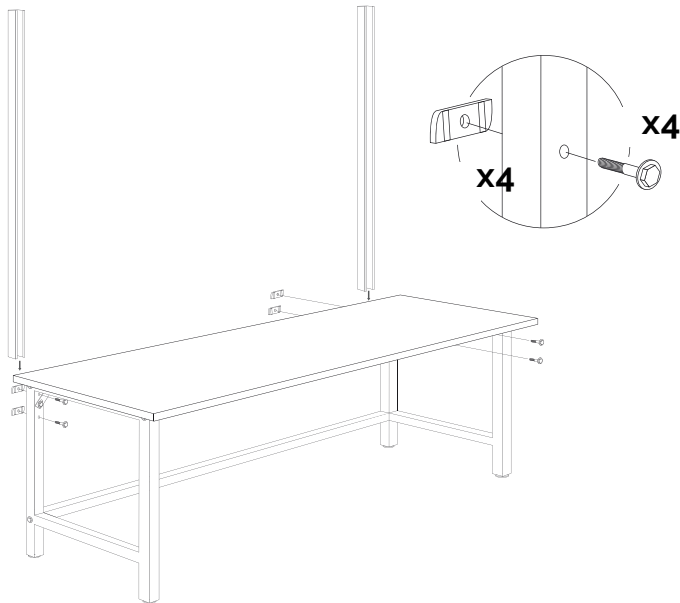

Insert bolts through back legs and loosely attach cone nuts in a horizontal position. Slide struts down over cone nuts and tighten bolts.

Meta los tornillos por atrás de las patas y ponga los pernos. Deslice las tuercas y apriete los tornillos.

With help of another person, insert bolts through light bracket and loosely attach cone nuts in a horizontal position. Insert cone nuts into struts from above.

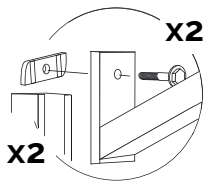

Con la ayuda de otra persona, inserte los pernos flojos a través de la escuadra y atornille ligeramente las tuercas del cono en una posición horizontal. Inserte las tuercas en los puntales por arriba del cono.

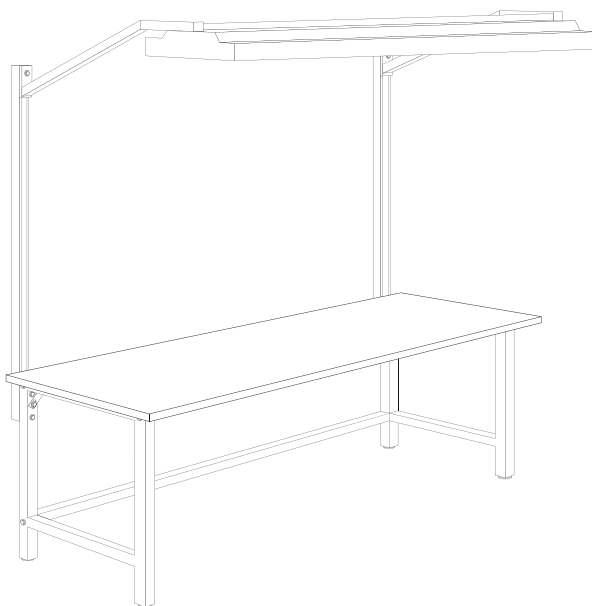
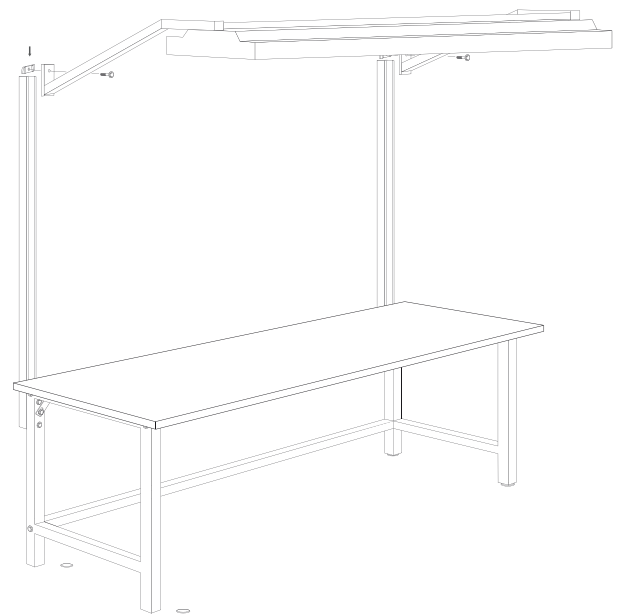

Tighten the bolts and plug in the powercord.

Apriete los pernos y enchufe el cordón eléctrico.

Monitor Mount Installation Instructions



7-FLEX ARTICULATING MONITORING MOUNT

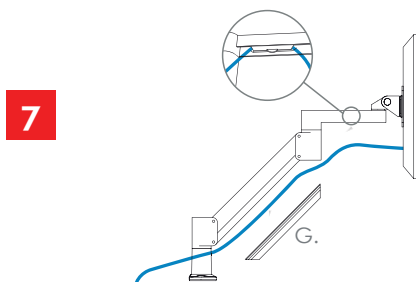
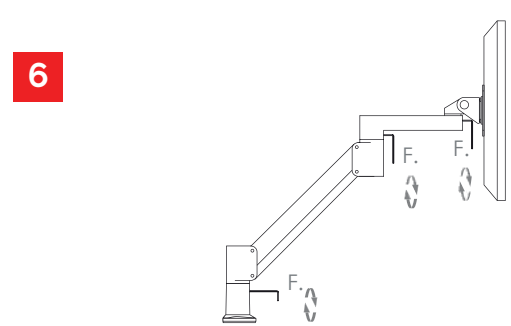
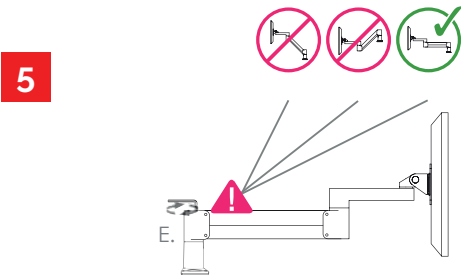
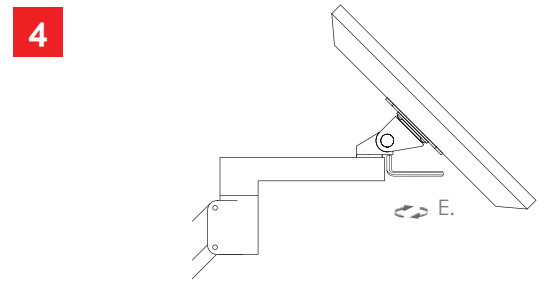
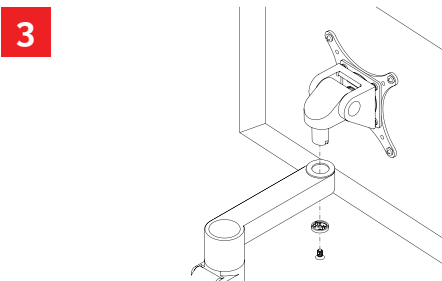
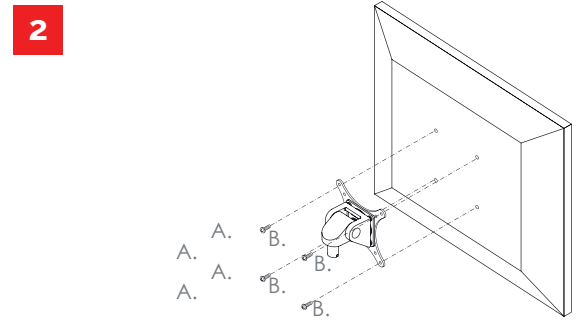
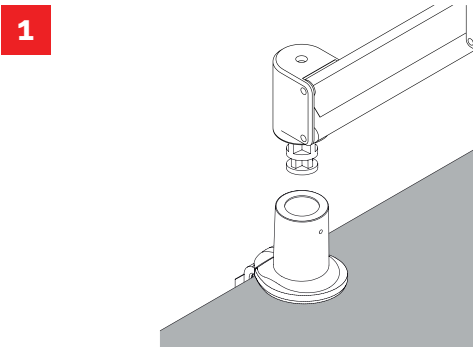

Monitor Mount Installation Instructions



DESK CLAMP

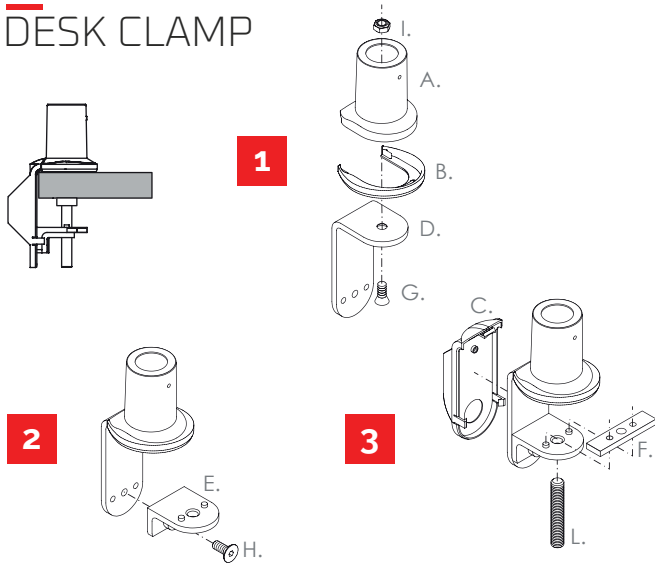

THRU-DESK

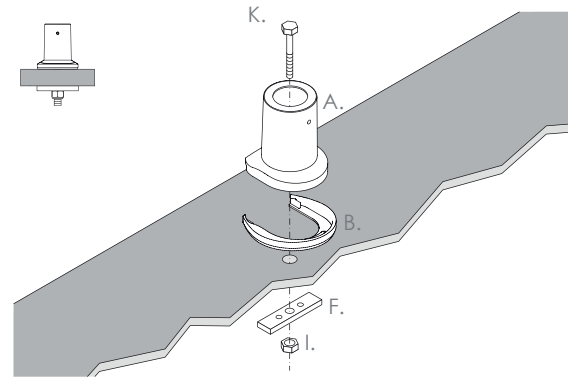

WALL MOUNT

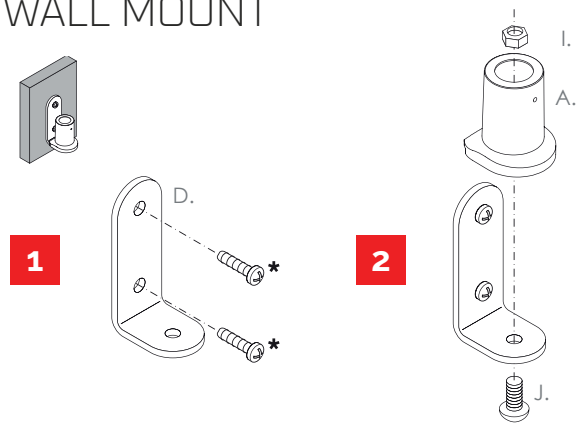

REVERSE WALL MOUNT

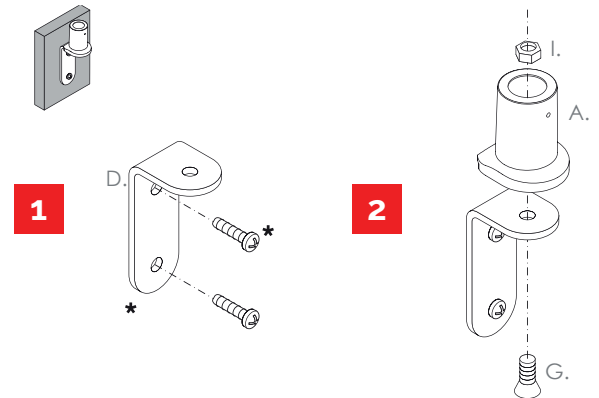

GROMMET HOLE

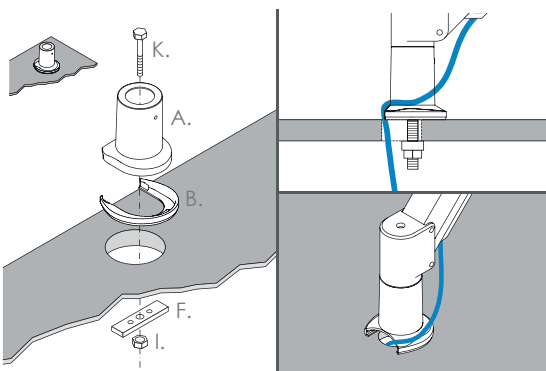

SIDE BOLT

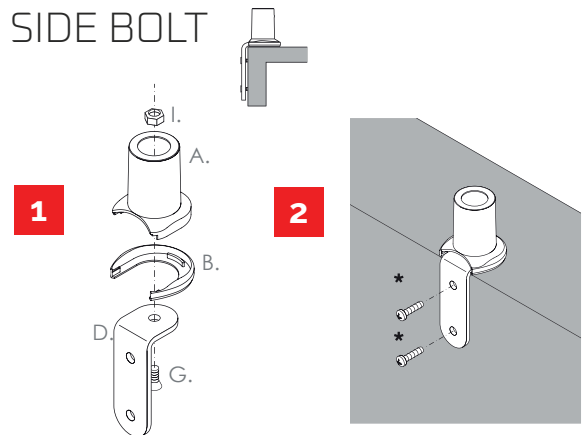

Monitor Mount Installation Instructions



LCD-4 MONITOR MOUNT

Insert bolts through back legs and loosely attach cone nuts in a horizontal position. Slide struts down over cone nuts and tighten bolts.

Meta los tornillos por atrás de las patas y ponga los pernos. Deslice las tuercas y apriete los tornillos.

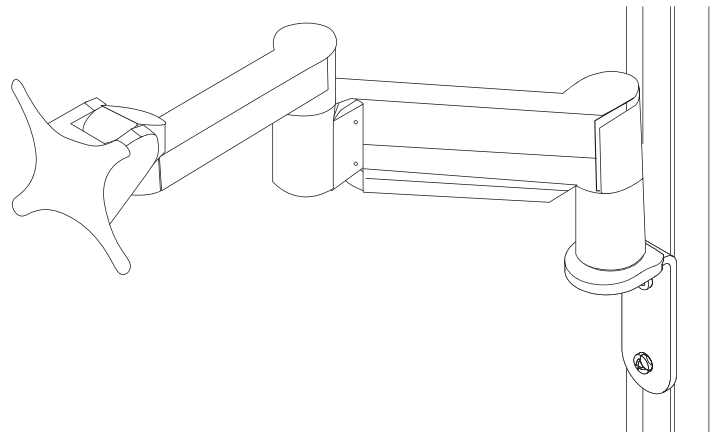
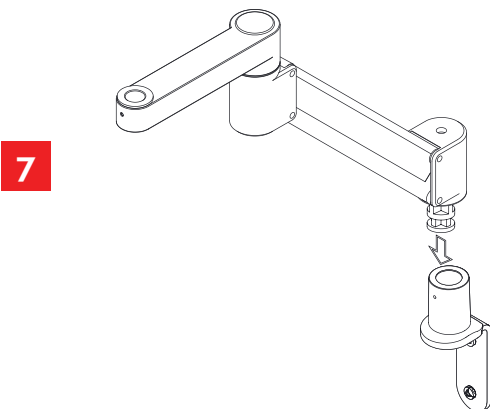
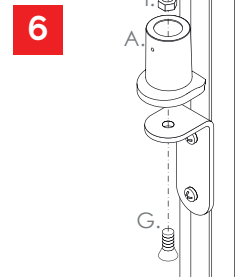
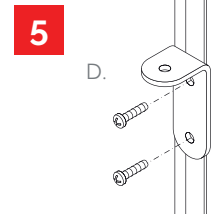
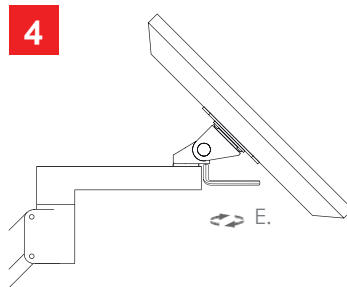
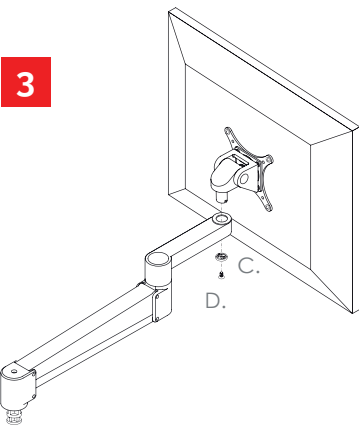
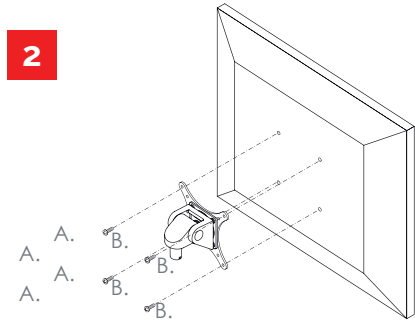
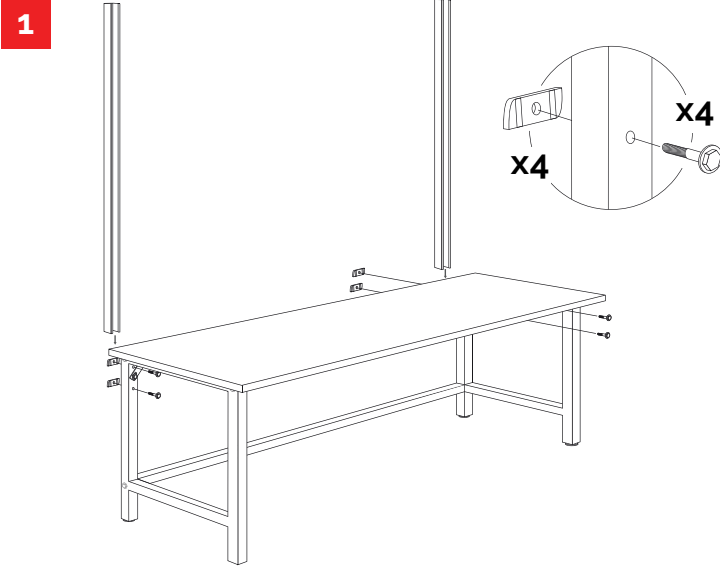

Monitor Mount Installation Instructions



STATIC MONITOR MOUNT

1

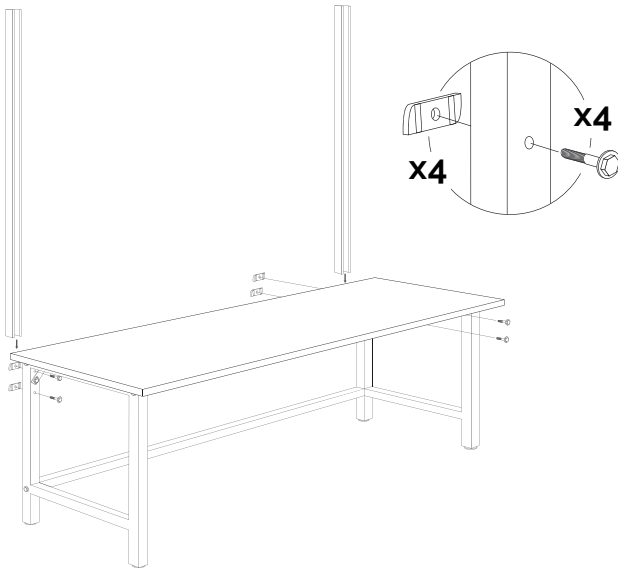

Insert bolts through back legs and loosely attach cone nuts in a horizontal position. Slide struts down over cone nuts and tighten bolts.

Meta los tornillos por atrás de las patas y ponga los pernos. Deslice las tuercas y apriete los tornillos.

2

Insert bolts through power strip and loosely attach cone nuts in a vertical position. Insert cone nuts into struts.

Ponga los tornillos a través del cordón eléctrico y meta las tuercas en posición vertical. Meta las tuercas en los puntales.

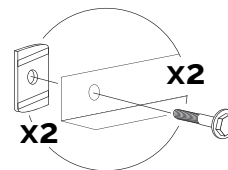

3

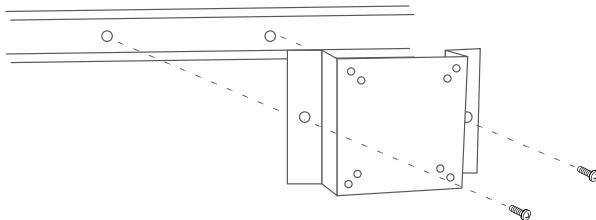

4

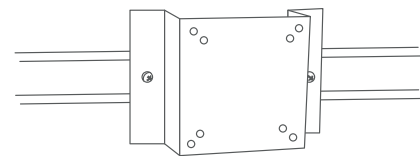

Bin Rail

Installation Instructions

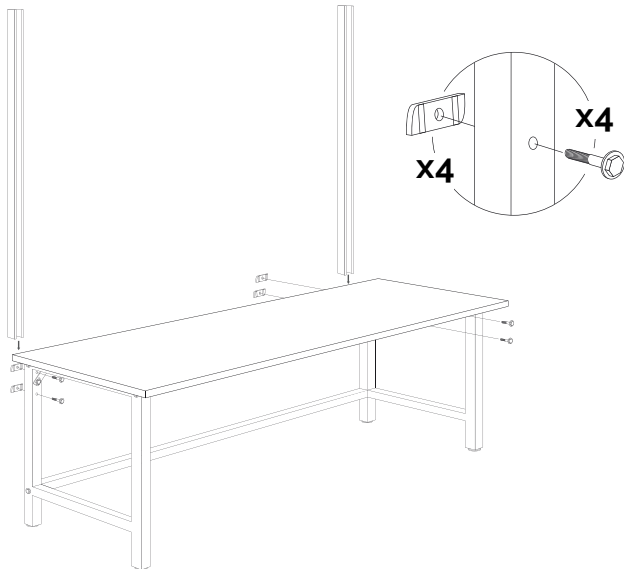

Insert bolts through back legs and loosely attach cone nuts in a horizontal position. Slide struts down over cone nuts and tighten bolts.

Meta los tornillos por atrás de las patas y ponga los pernos. Deslice las tuercas y apriete los tornillos.

Insert bolts through bin rail and loosely attach cone nuts in a vertical position. Insert cone nuts into struts.

Meta los tornillos a través del carril del compartimiento y atornille sueltamente las tuercas en posición vertical. Meta las tuercas dentro de los puntales.

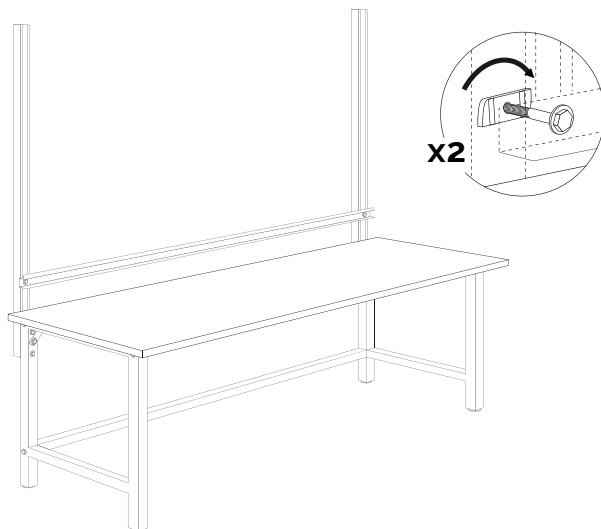
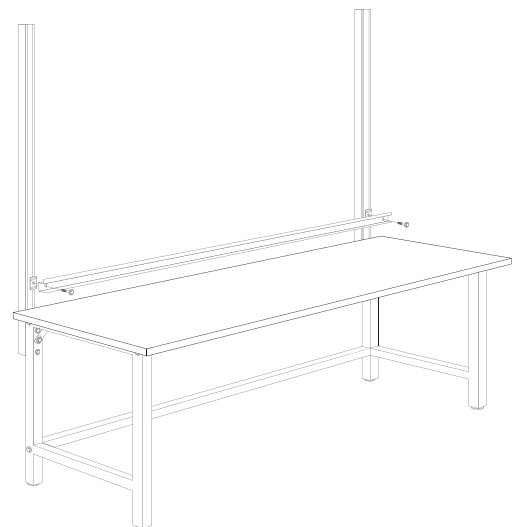
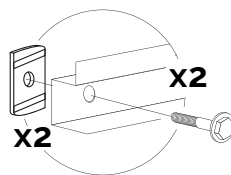

Rotate cone nuts to a horizontal position inside the strut and tighten bolts.

Atornille las tuercas del cono hasta que estén en una posición horizontal dentro del puntal y apriete los tornillos.

Keyboard Installation Instructions

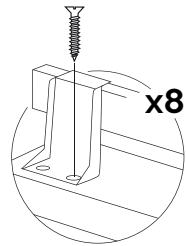

Attach Keyboard to buildup blocks.
Conecte el teclado a los bloques.

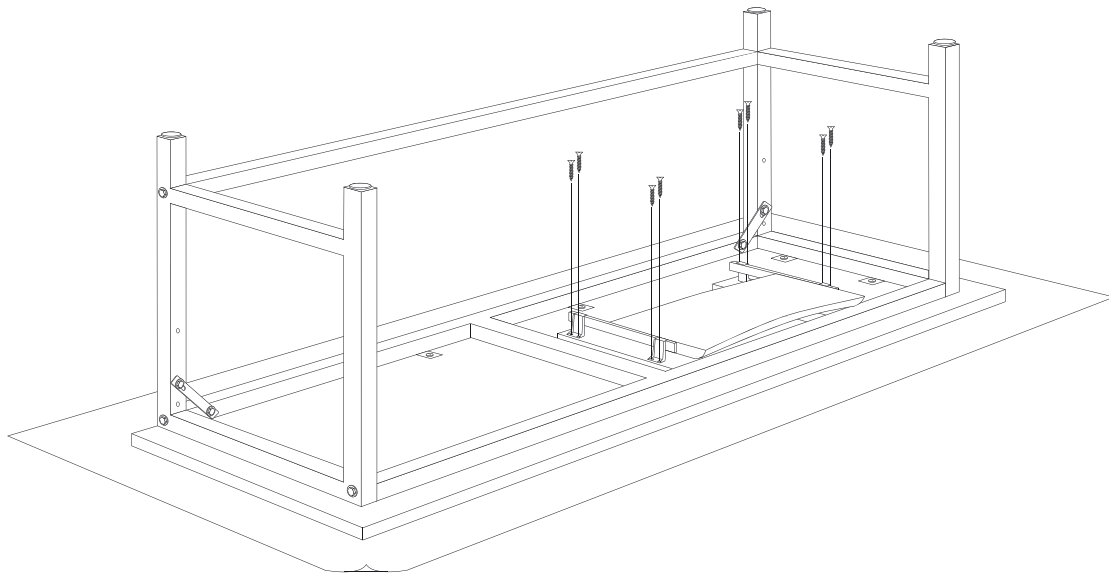

File/Utility Drawer Installation Instructions

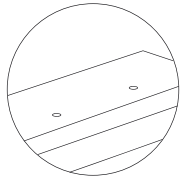

Locate the buildup blocks located underneath the workbench.

Localice los bloques colocados abajo de la banca de trabajo.

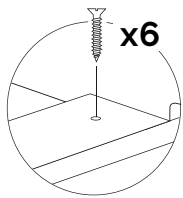
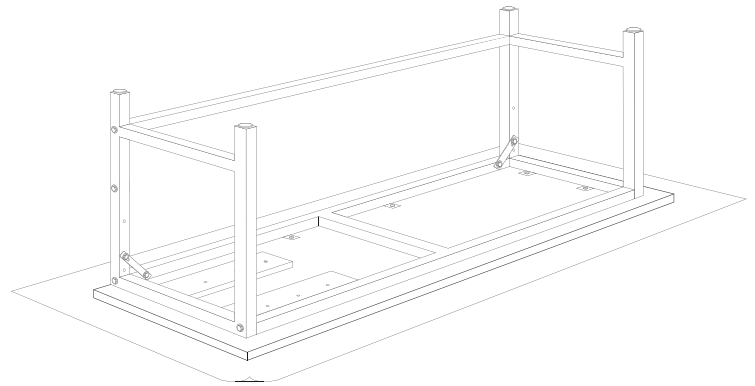

Remove the drawers and place the cabinet on the buildup blocks. Screw the cabinet to the buildup blocks.

Saque los cajones y coloque el gabinete sobre los bloques. Atornille el gabinete a los bloques.

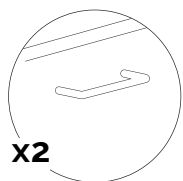
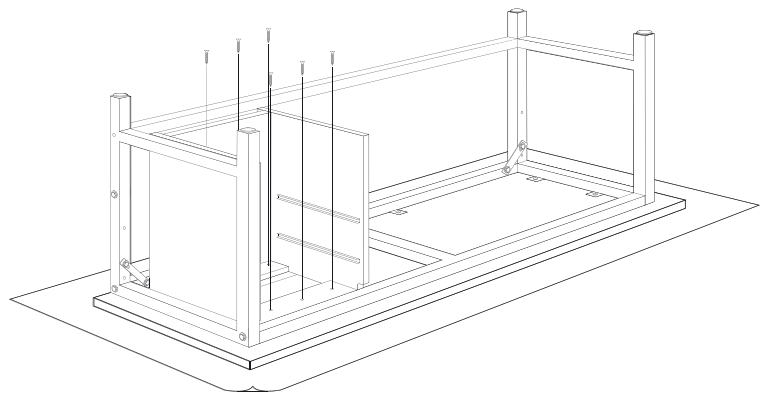

Remove the handles from the insides of the drawers and place on the outsides of the drawers. Insert the drawers into the cabinet.

Remueva las palancas (mango) que se encuentran adentro de los cajones y colóquelos afuera de los cajones.

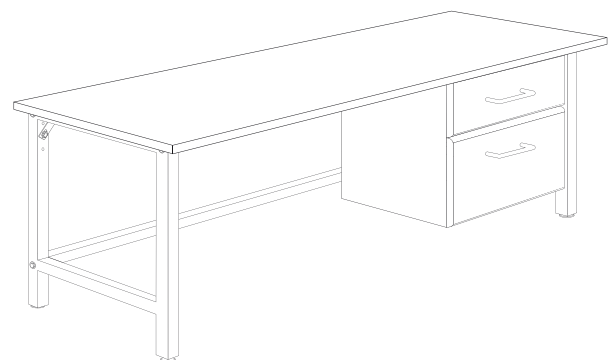

Lower Shelf Installation Instructions

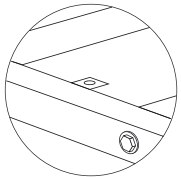

Locate the the tabs located underneath the workbench.

Localizar las orejas debajo de la banca de trabajo.

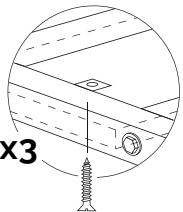
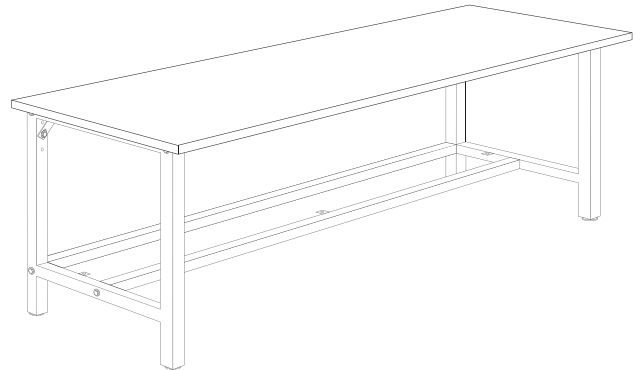

Place the drawer on the lower section of the workbench and screw the tabs to the shelf.

Colocar el cajón en la sección baja de la banca de trabajo y atornille las orejas al anaquel.

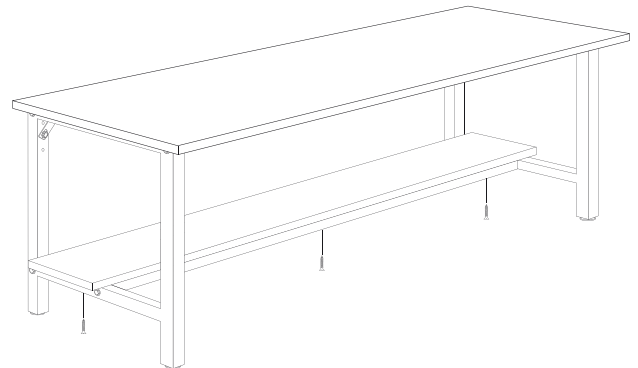

- ▶ 800-298-0473
- ▶ CREATE@WORKBENCHES.COM
- ▶ WORKBENCHES.COMCOM
- ▶ 5900 BALCONES DRIVE
#24081 AUSTIN, TX 78731



We Get the Job Done.