

Seat Assembly

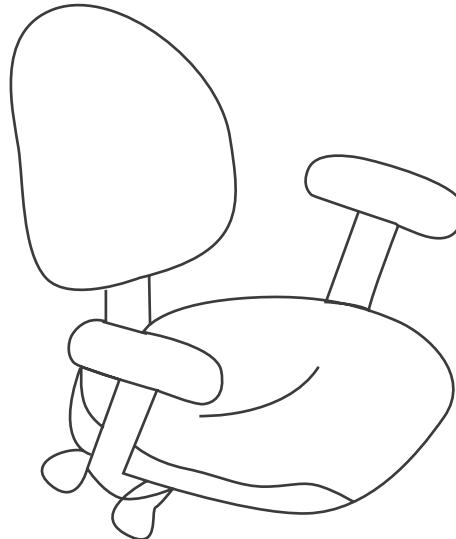

Barrel



Adjustable Footring  
(Not available on Desk Height)

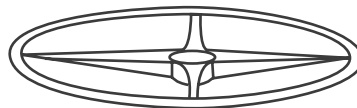

Base

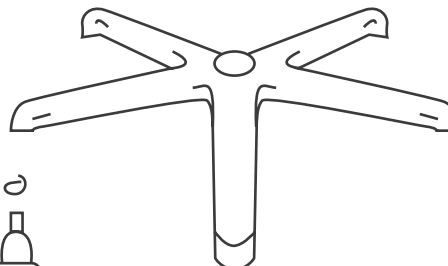

Glides or Dual Wheels and Casters



## Step 1

Turn base up-side down.

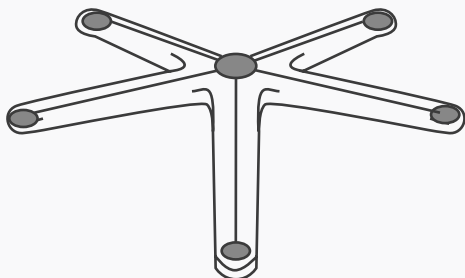

## Step 2

Firmly push a glide/caster into each of the holes at the end of the 5 base legs.

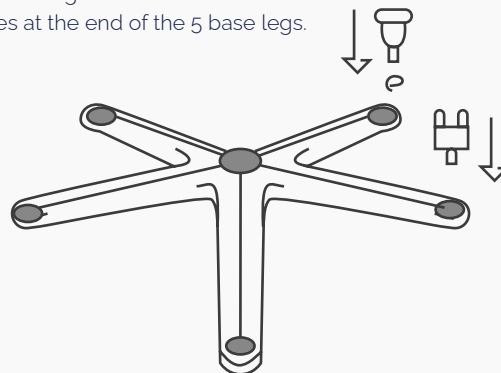

## Step 3

Turn the base right side up. Firmly insert the barrel into the base.

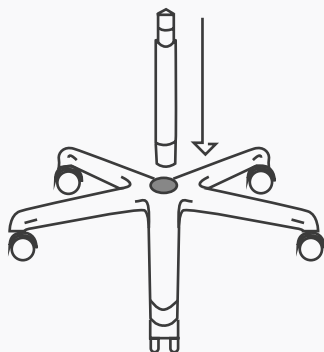

## Step 4

ONLY FOR CHAIRS WITH ADJUSTABLE FOOTRING OPTION. Place the adjustable footring on the barrel and tighten it. It can be adjusted for height after the chair has been fully assembled.

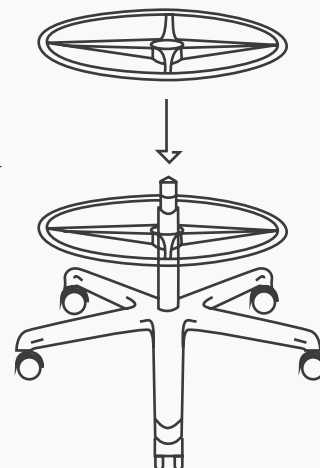

## Step 5

Place the seat on the barrel. The easiest and safest way to do this is to turn the chair upside down and push the base/barrel assembly into the hole in the chair mechanism. For a standard size chair, hold the barrel cover on the barrel as you insert it in the assembly. Be sure to lodge the parts together securely.

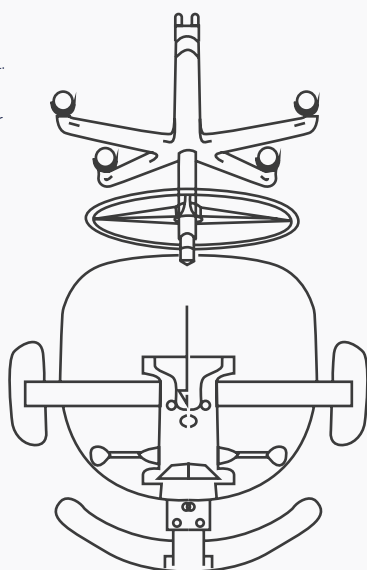

## Step 6

Gently roll your chair right side up. If necessary, adjust the footring to a comfortable height. Check to make sure all parts are fully and securely assembled.



- ▶ 800-298-0473
- ▶ CREATE@WORKBENCHES.COM
- ▶ WORKBENCHES.COM
- ▶ 5900 BALCONES DRIVE  
#24081 AUSTIN, TX 78731



We Get the Job Done.